

Solid State Broadband High Power Amplifier

2154 – BBS2E6ARR
20 – 3000 MHz / 500 Watts

The BBS2E6ARR (SKU 2154) is suitable for ultra broadband high power applications, laboratory, and RFI/EMC susceptibility testing. This dual band amplifier utilizes push-pull LDMOS devices for 20-1000MHz band and GaN devices for 1000-3000MHz band frequency. Employing advanced broadband RF matching networks and combining techniques, EMI/RFI filters, and all qualified components achieved exceptional performance, and high efficiency. The system includes a universal voltage, single phase, power supply and a built in forced air-cooling system. Empower RF's ISO9001 Quality Assurance Program assures consistent performance and the highest reliability.



- Solid-state Class AB design
- Instantaneous ultra broadband
- Small form factor and lightweight
- 50 ohm input/output impedance
- High reliability and ruggedness
- Built-in control, monitoring and protection circuits
- Suitable for CW, AM and FM (Consult factory for other modulation types)

ELECTRICAL SPECIFICATIONS @ 220V_{AC}, 25°C, 50 Ω System

Parameter	Symbol	Min	Typ	Max	Unit
Operating Frequency (Dual Band)	Low Band	BW ₁	20		MHz
	High Band	BW ₂	1000		
Output Power CW	P _{SAT1}	500			Watt
	P _{SAT2}	250			
Output Power @ P _{1dB} Gain Compression	P _{1dB1}	300			Watt
	P _{1dB2}		120		
Power Gain @ P _{1dB}	G _{1dB1}	56			dB
	G _{1dB2}	54			
Input Power for Rated P _{SAT}	P _{IN}		0		dBm
Small Signal Gain Flatness	P _{IN=} @ -20dBm	ΔG ₁			dB
	P _{IN=} @ -10dBm	ΔG ₂		±2.0	
Gain Adjustment Range	FGA	20	25		dB
Input Return Loss	S ₁₁			-10	dB
Noise Figure	NF ₁		10	15	dB
	NF ₂		10	20	dB
Third Order Intercept Point 2-Tone @ 100kHz Spacing	50dBm/Tone	IP _{3,1}	+60		dBm
	47dBm/Tone	IP _{3,2}	+63		
Harmonics @	P _{OUT} = 300W	2 ND / 3 RD ₁	-30/-20		dBc
	P _{OUT} = 120W	2 ND / 3 RD ₂	-20/-30		
Spurious Signals	Spur		-70	-60	dBc
Operating Voltage (single phase)	V _{AC}	180		260	Volt
Power Consumption	@ 500W, CW	P _{D1}		3650	Watt
	@ 250W, CW	P _{D2}		1850	Watt

Solid State Broadband High Power Amplifier

2154 – BBS2E6ARR
20 – 3000 MHz / 500 Watts

MECHANICAL SPECIFICATIONS

Parameter	Value	Units	Limits
Dimensions (W x H x D)	19 x 19.25 x 22	Inch	Max
Weight	210 (Rack Slides Included)	lbs.	Max
RF Connector Input	Type-N female		
RF Connector Output	Type-N female		
Communication Connector	RJ-45 Ethernet 10/100Mbps		
I/O Control Connector	D-Sub 9-Pin, Female		
AC Power Connector	MIL-STD Circular Connector, Male		
Cooling	Built-in Forced Air Cooling System		
LCD Controller	Local: Front panel touch screen color LCD controller including FWD/REV Power indication (dBm or Watt scale), VSWR, Gain Adjustment, ALC Fast/Slow & On/Off, Standby mode, Fault indication. Remote: Ethernet and RS-232 serial interface.		

ENVIRONMENTAL CHARACTERISTICS (Design to Meet)

Parameter	Symbol	Min	Typ	Max	Unit
Operating Ambient Temperature	T _C	0		+50	°C
Storage Temperature	T _{STG}	-40		+85	°C
Relative Humidity (non-condensing)	RH			95	%
Altitude (MIL-STD-810F Method 500.4)	ALT			30,000	Feet
Vibration/Shock MIL-STD-810F - Method 514.5/516.5 – Proc I	VI/SH		Airborne		-

LIMITS

Parameter	Specifications	Unit
Input RF drive level without damage	+10 dBm	Max
Load VSWR @ P _{OUT}	∞ @ all load phase & Amplitude for duration of 1 minute 3:1 @ all load & amplitude continuous	-
Thermal Overload	85°C shutdown	Max

I/O CONTROL CONNECTOR – D-Sub 9-Pin, Female

Pin #	Description	Specification	Options	
			FGA	LCD
1	Forward Test Point	Analog Voltage 0-5V _{DC} relative to Forward Power Level		√
2	Reverse Test Point	Analog Voltage 0-5V _{DC} relative to Reverse Power Level		√
3	5V Test Point	+5.0V _{DC} , ±0.5V	√	√
4	VVA Test Point	VVA Gain Control +5.6V _{DC} , ±0.2V	√	
5	EXT Shutdown	Amplifier Disable: TTL Logic High (5V) (Internally Pulled-Low)	√	√
6	12V Test Point	+12.0V _{DC} , ±1.0V	√	√
7	P/S Test Point	P/S Output Voltage +28.0V _{DC} , ±2.0V	√	√
8	GND	Ground	√	√
9	GND	Ground	√	√

Solid State Broadband High Power Amplifier

2154 – BBS2E6ARR

20 – 3000 MHz / 500 Watts

System Block Diagram

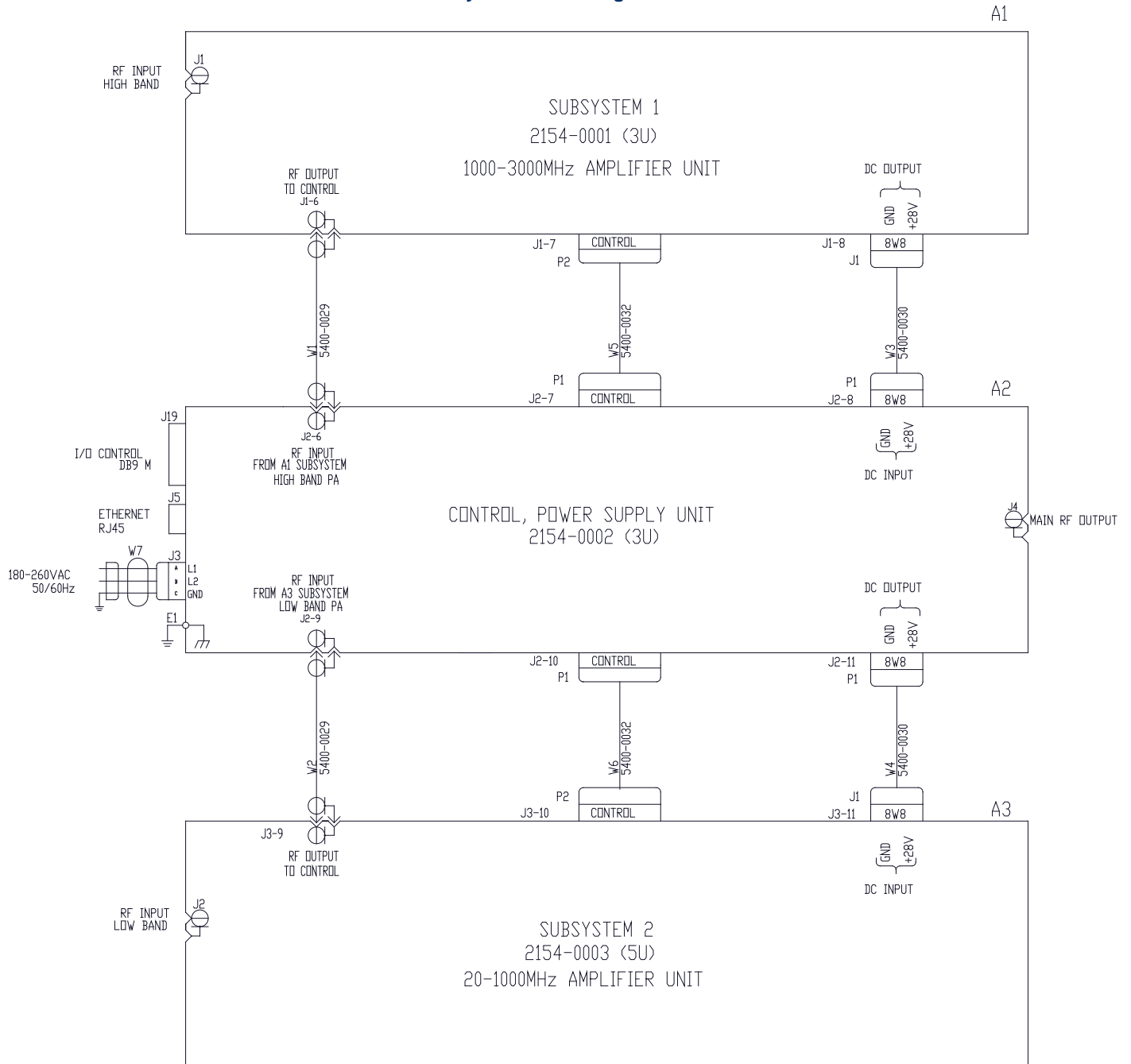

Solid State Broadband High Power Amplifier

2154 – BBS2E6ARR

20 – 3000 MHz / 500 Watts

System Outline Drawing

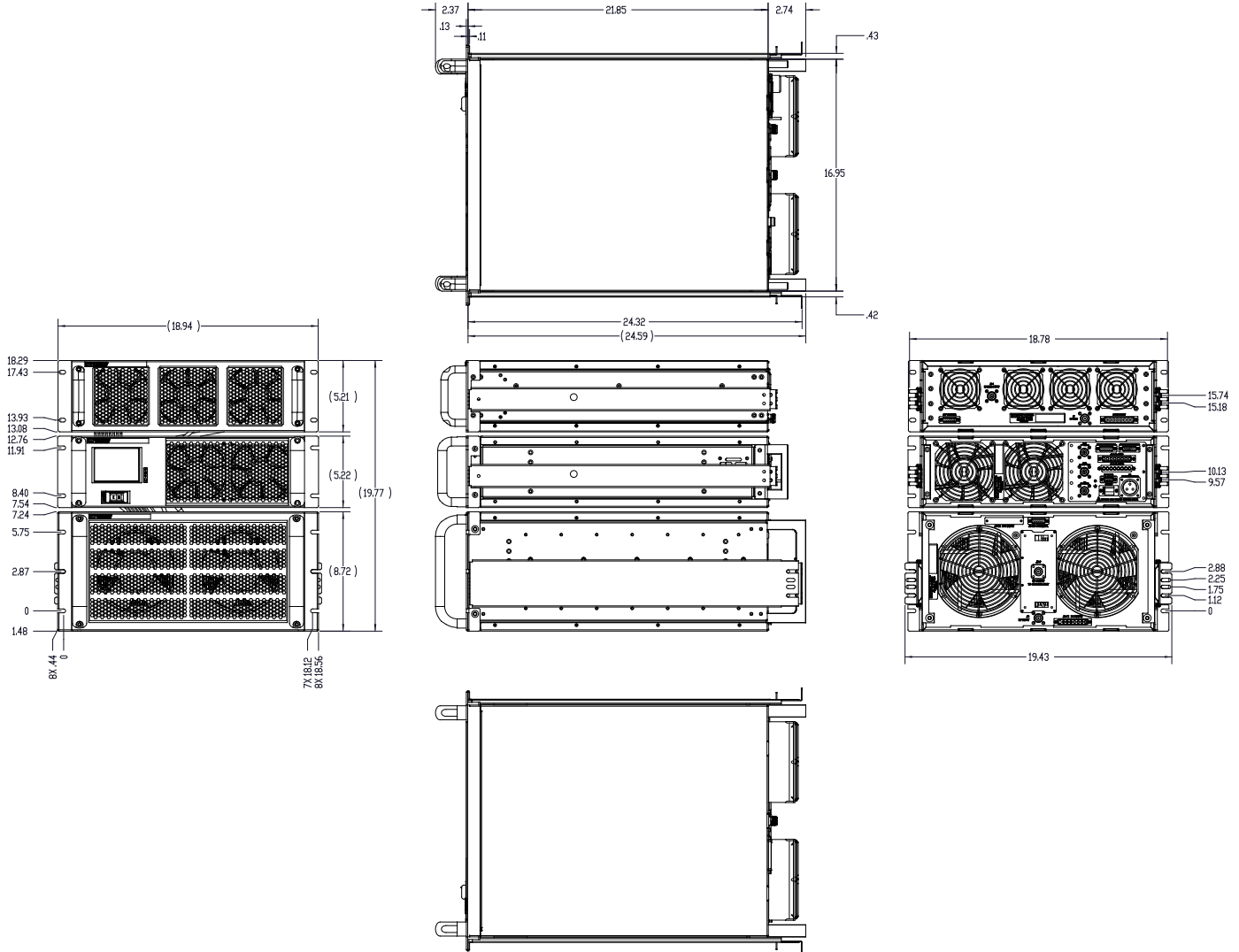

Solid State Broadband High Power Amplifier

2154 – BBS2E6ARR

20 – 3000 MHz / 500 Watts

Performance Plots – Low Band

Plot 1 – Small Signal Gain and P_{1dB}

Top Curve: Small Signal Gain @ $P_{IN} = -20dBm$
 Middle Curve: Power Gain @ P_{1dB} , $P_{IN} = -3dBm$
 Reference: 59dB, 1dB/Div.
 Bottom Curve: Input Return Loss
 Reference: 0dB, 10dB/Div.

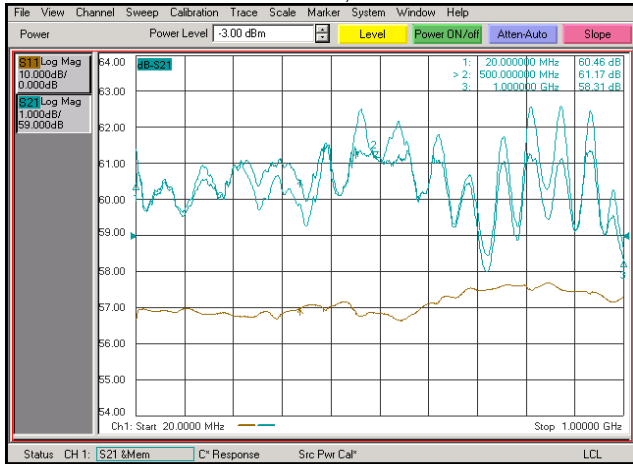

Plot 2 – Small Signal Gain and P_{SAT}

Top Curve: Small Signal Gain @ $P_{IN} = -20dBm$
 Middle Curve: Power Gain @ P_{SAT} , $P_{IN} = -0.5dBm$
 Reference: 59dB, 1dB/Div.
 Bottom Curve: Input Return Loss
 Reference: 0dB, 10dB/Div.

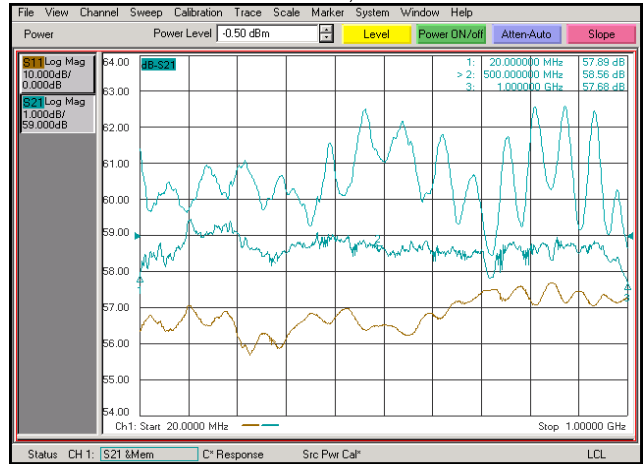

Plot 3 – Gain Adjustment Range

Top Curve: Maximum Gain @ $P_{IN} = -20dBm$
 Middle Curve: VVA @ Minimum Gain
 Reference: 29dB, 10dB/Div.
 Bottom Curve: Input Return Loss @ Minimum Gain
 Reference: 0dB, 10dB/Div.

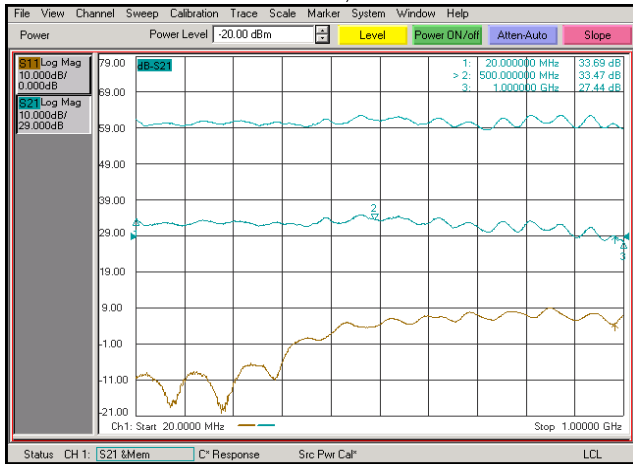

Plot 4 – ALC Flatness

Top Curve: ALC @ 250W, $P_{IN} = 0dBm$
 Bottom Curve: ALC @ 50W, $P_{IN} = 0dBm$
 Reference: 51dB, 1dB/Div.
 Middle Curve: Input Return Loss @ ALC = 50W
 Reference: 0dB, 10dB/Div.

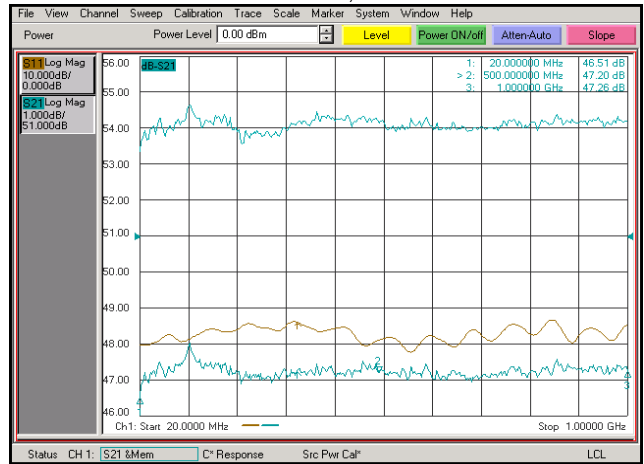

Solid State Broadband High Power Amplifier

2154 – BBS2E6ARR

20 – 3000 MHz / 500 Watts

Performance Plots – High Band

Plot 5 – Small Signal Gain and P_{1dB}

Top Curve: Small Signal Gain @ $P_{IN} = -10dBm$
 Middle Curve: Power Gain @ P_{1dB} , $P_{IN} = -5dBm$
 Reference: 57dB, 1dB/Div.
 Bottom Curve: Input Return Loss
 Reference: 0dB, 10dB/Div.

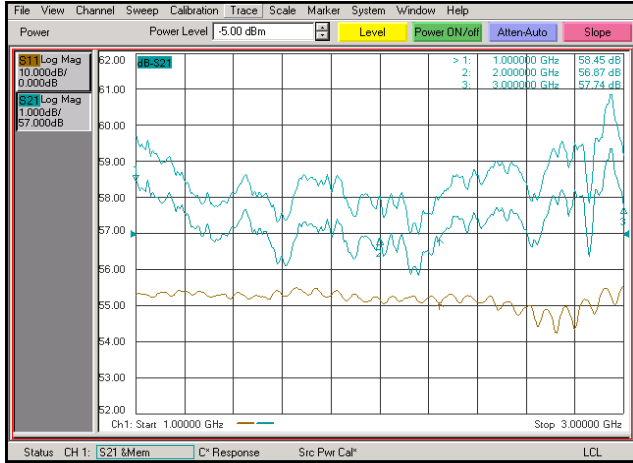

Plot 6 – Small Signal Gain and P_{SAT}

Top Curve: Small Signal Gain @ $P_{IN} = -10dBm$
 Middle Curve: Power Gain @ P_{SAT} , $P_{IN} = 0dBm$
 Reference: 57dB, 1dB/Div.
 Bottom Curve: Input Return Loss
 Reference: 0dB, 10dB/Div.

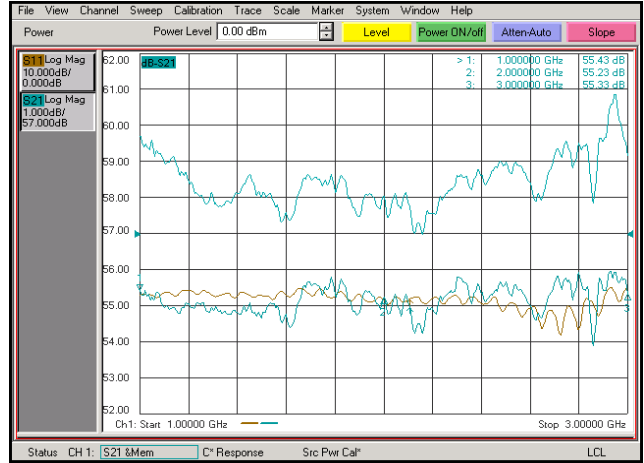

Plot 7 – Gain Adjustment Range

Top Curve: Maximum Gain @ $P_{IN} = -10dBm$
 Middle Curve: VVA @ Minimum Gain
 Reference: 27dB, 10dB/Div.
 Bottom Curve: Input Return Loss @ Minimum Gain
 Reference: 0dB, 10dB/Div.

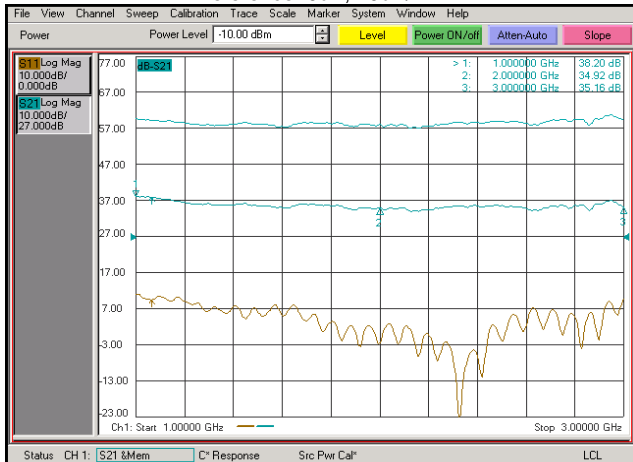

Plot 8 – ALC Flatness

Top Curve: ALC @ 125W, $P_{IN} = 0dBm$
 Bottom Curve: ALC @ 25W, $P_{IN} = 0dBm$
 Middle Curve: Input Return Loss @ ALC = 25W
 Reference: 0dB, 10dB/Div.

