

# PEARSON™ POWERLINE RIPPLE DETECTOR PRD-120

- Accurate measurement of audio frequency (CS101) ripple injected on AC or DC power buses
- Separates injected ripple from the power waveform.
- Used with a spectrum analyzer, simplifying the measurement process.
- Maximum voltage, 120 Volts AC or DC
- Switch-selectable frequency response:
  - Flat response from 10 Hz to 150 kHz
  - CS101 profile for setting the ripple level above 5 kHz

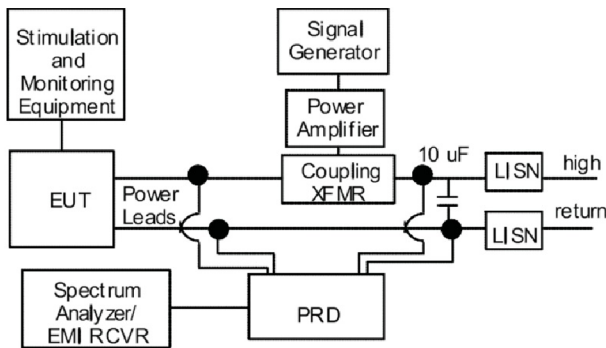

**FLAT FREQUENCY RESPONSE**  
TRANSDUCER FACTOR

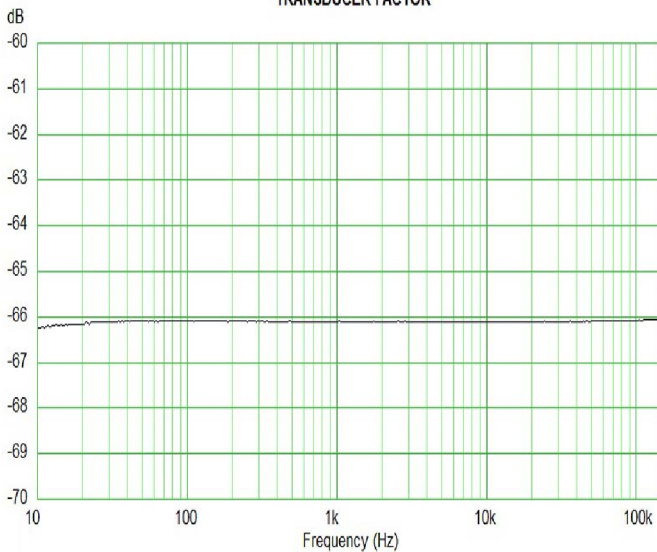

**CS101 RESPONSE**  
TRANSDUCER FACTOR

